



REPLACING THE HUMAN BRAIN: WILD IDEA PROMISES INCREDIBLE FUTURE

DICK PELLETIER

*Futurist and science/technology columnist, Las Vegas, NV.
PositiveFuturist.com*

Dick Pelletier asserts, given the predicted growth and development in nanotechnology, that by 2050 we will be able to replace neurons in our brains with non-biological neurons thereby enhancing our capacities in computation, cognition, memory, communication and overall consciousness.

Keywords: Brain cells, non-biological, neuron, carbon, nanotubes, synapse, computer, plasticity, consciousness, reverse-engineering, Blue Brain Project, simulate, machine, singularity, Kurzweil, cerebral cortex, cognition, IBM, supercomputer, memory, John Burch, nanofactory, nanosystems, nanotechnology, nanoseconds, nanobot, cyborg.

As crazy as this idea may seem, in the not-to-distant future, replacing brain cells with non-biological neurons could enable humans to survive nearly any accident, and as a bonus, acquire new abilities.

Researchers at *USC's Viterbi School of Engineering* have created a functioning synapse¹ using neurons made from carbon nanotubes. In tests, their synapse circuits perform similar to normal biological neurons.

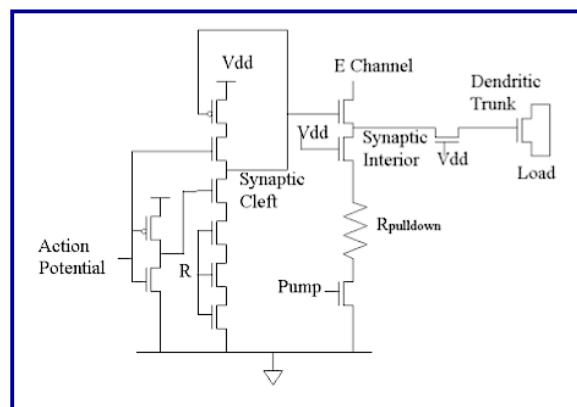

Credit: Aaron K. Friesz, Alice C. Parker, Chongwu Zhou, Koungmin Ryu and Jason M. Sanders
<http://eve.usc.edu/Publications/cntfinal2.pdf>

¹ Functioning Synapse Created Using Carbon Nanotubes, <http://neurosciencenews.com/synapse-using-carbon-nanotubes-synthetic-brain/>, retrieved July 30, 2012

Of course, duplicating synapse firings in nanotube circuits does not mean that scientists are ready to replace the brain now. This organ is extremely complex. Unlike the static inner workings of computers, brains are constantly making new neurons and connections as they adapt to changing environments. This plasticity, as it is referred to, cannot be duplicated with today's limited understanding of consciousness.

However, while a fully-functioning synthetic brain may be years away, the artificial synapse is here now, and this achievement could one day help scientists unravel many of the mysteries of consciousness, and learn more about how events in our brains give rise to the life in our minds.

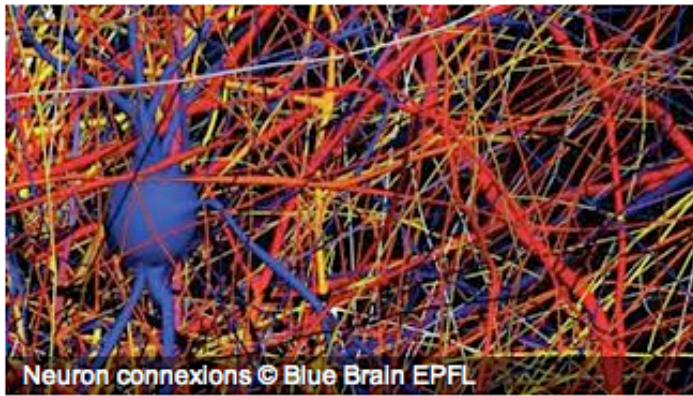

22.03.11 - Do we have innate knowledge? Neuroscientists working on Blue Brain Project at EPFL (Ecole Polytechnique Fédérale de Lausanne) are finding proof that this is the case. They've discovered that neurons make connections independently of a subject's experience. Their results have been published in an article in the Proceedings of the National Academy of Sciences (PNAS).

Credit: <http://actu.epfl.ch/news/new-evidence-for-innate-knowledge-5/>

Reverse-engineering the brain, a massive effort called the “*Blue Brain Project*”², with completion hoped for by 2023, will enable scientists to simulate the brain in a machine. This is the first step in creating machines more powerful than the human brain, predicts Ray Kurzweil, author of *The Singularity is Near*³.

“The key lies in decoding and simulating the cerebral cortex, the seat of cognition,” Kurzweil says; “The human cortex has about 22 billion neurons and 220 trillion synapses.” Today, computers capable of crunching this amount of data do not exist, but IBM experts believe that supercomputers with increased computational and memory capacity that can process this data will be available in the coming years.

Nanoengineer, John Burch, co-designer of the nanofactory video, *Productive Nanosystems*⁴, predicts in his blog⁵ that expected advances in molecular nanotechnology will one day enable us

² Markram, H. Blue Brain Project. [2012] <http://www.artificialbrains.com/blue-brain-project>, retrieved July 30, 2012

³ Kurzweil, R. [2005] *The Singularity Is Near* (Viking, New York).

⁴ Sims, M. (CEO of Nanorex, Inc.). [2006] *Productive Nanosystems: From molecules to superproducts*. <http://video.google.com/videoplay?docid=-2022170440316254003>, retrieved July 30, 2012

⁵ Burch, J. [2006] “Brain Augmentation via nano robots,” *Nano Future 2030*. <http://www.nanofuture2030.com/?p=12&cpage=1>, retrieved July 30, 2012

to replace brain cells with damage-resistant nanomaterials that process thoughts faster than today's biological brains.

"The new brain would include an exact copy of the structure and personality that existed before the conversion," Burch says, but it would run much faster and would increase our memory a thousand-fold. We could even control the speed of our thoughts, shifting from 100 milliseconds, the response time of today's brains, to fifty nanoseconds, millions of times faster.

Creating thoughts at high speeds would slow everything down; at least that's how it would seem in our mind. Our perception would quicken, but activities would appear to happen slower. Events that seem like minutes in our mind would actually be happening in seconds. We would no longer panic in emergencies.

Burch describes how we would switch to this new brain. A daily pill would supply nanomaterials and instructions for nanobots to form new neurons and position them next to existing brain cells to be replaced. These changes would be unnoticeable to us, but in six months, we would sport the new brain.

Our artificial brain would allow wireless interface with computers and other digital technologies. We could access the Internet, control electronics, and make phone calls, with just our thoughts. In addition, we would learn new complicated subjects; even speak a different language, without need for study.

The most important benefit of our new brain would be its ability to survive disaster. Should we suffer a fatal accident, our body may be a total loss, but the moment the accident happened; nanobots would quickly repair our brain, if damaged. Information would then be transmitted to a process center, ordering construction of a new body, ready for the transfer of our new or repaired brain with memories intact.

The accident victim would 'wake up,' not even realizing they had died. Biological brains die within minutes after the heart stops, but our new brain will simply turn itself off and wait for a new power supply.

Experts predict these technologies could be in place by as early as 2050; or for sure, sometime during the last half of the 21st century; however, will this make us less human; are we becoming cyborgs.

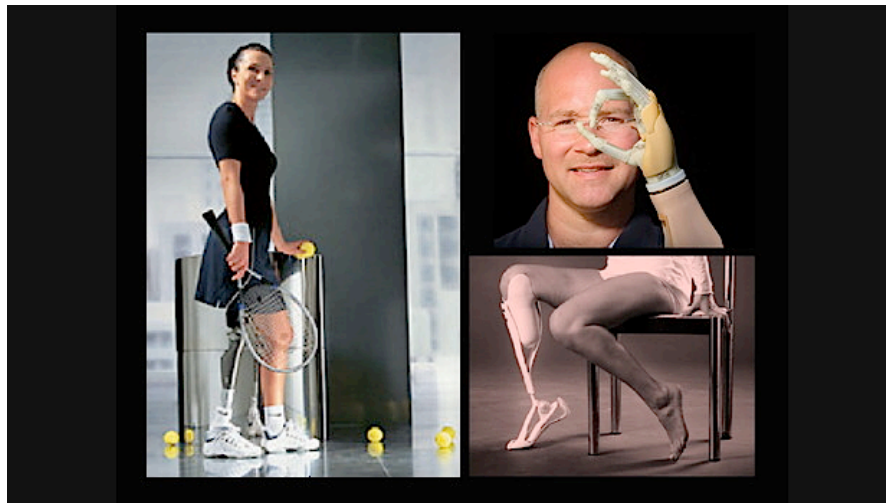

Credits: c_leg_285x250_rdax_85.jpg (public domain); <http://bit.ly/LWooKD>; <http://bit.ly/Lqq1yA>

Proponents explain that we already enjoy glasses, false teeth, titanium hips, cochlear implants, and prosthetic limbs. Artificial brains are just the next stage in making our future high-tech life more secure.

Does this radical technology make sense to you? Personally, once I get over the “yuck” factor of replacing my brain I see this as an incredible life-saving medical procedure. It may sound more like fiction than science, but this could become our future.

References

- Burch, J. [2006] “Brain Augmentation via nano robots,” *Nano Future 2030*.
<http://www.nanofuture2030.com/?p=12&cpage=1>, retrieved July 30, 2012
- Mankin, E. [2012] *Functioning Synapse Created Using Carbon Nanotubes*
(NeuroscienceNews.com) <http://neurosciencenews.com/synapse-using-carbon-nanotubes-synthetic-brain/>, retrieved July 30, 2012.
- Markram, H. Blue Brain Project. [2012] <http://www.artificialbrains.com/blue-brain-project>,
retrieved July 30, 2012
- Kurzweil, R. [2005] *The Singularity Is Near* (Viking, New York).
- Sims, M. (CEO of Nanorex, Inc.). [2006] *Productive Nanosystems: From molecules to superproducts*. <http://video.google.com/videoplay?docid=-2022170440316254003>,
retrieved July 30, 2012